

MARICOPA COUNTY
HOME & LANDSCAPE SHOW

September 28-30, 2012
 Arizona State Fairgrounds
 602-485-1691

Overview

McDowell Road

McDowell Road

All indoor booths are \$10.30 per square foot for inlines and \$15.45 per square foot for corners. Outdoor booths are 20x20, \$1545.00 for open outdoor booths and \$2060.00 for outdoor undercover booths. All booths plus 2.6% tax.

A deposit is required to hold booth a space and custom payment plans are available. Ask your account manager.

September 28-30, 2012
Arizona State Fairgrounds
602-485-1691

AG Bldg 1 & 2

All booths are **10x10** unless noted:

10x10
\$1030.00 inline
\$1545.00 corner

8x10
700-734, 740-774, 856-862
\$824.00 inline
\$1236.00 corner

5x10
1008-1010 \$772.50 corner
1011-1012 \$515.00 inline
Booth area starts in front of the support poles and wires

706 is a 8x15=\$1854
769 A is a 8x8=\$659.20
775 is a 10x8=\$824
735A is a 5x10 corner=\$772.50
980-981 are 10x9's inline = \$927

Pavilion Corner
853, 864, 877, 1006 \$2575.00
Pavilion booths are already discounted and do not qualify for the multiple booth discount.

Multiple Booth Discount:
2-5 booths 10%
6 or more 15%

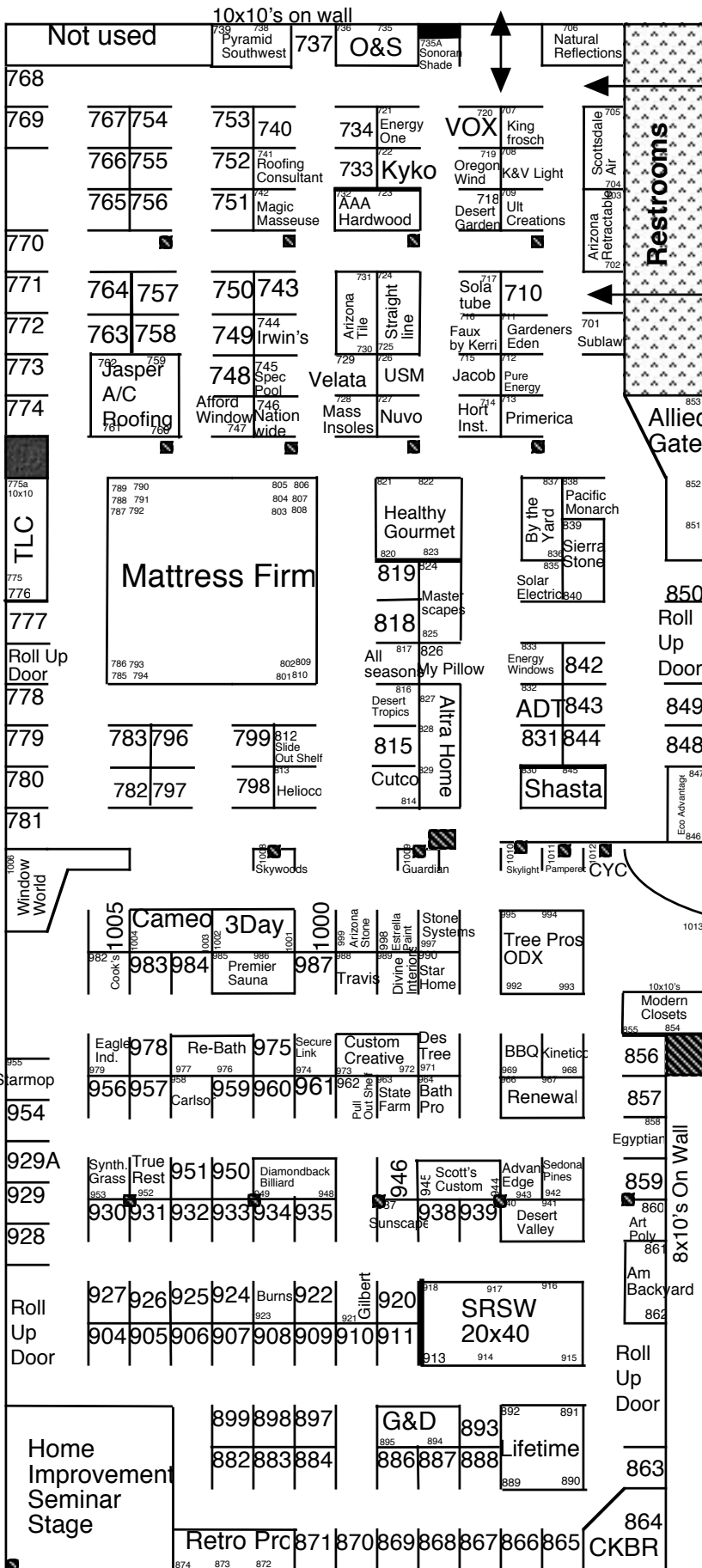

MARICOPA COUNTY HOME & LANDSCAPE SHOW

September 28-30, 2012
Arizona State Fairgrounds
602-485-1691

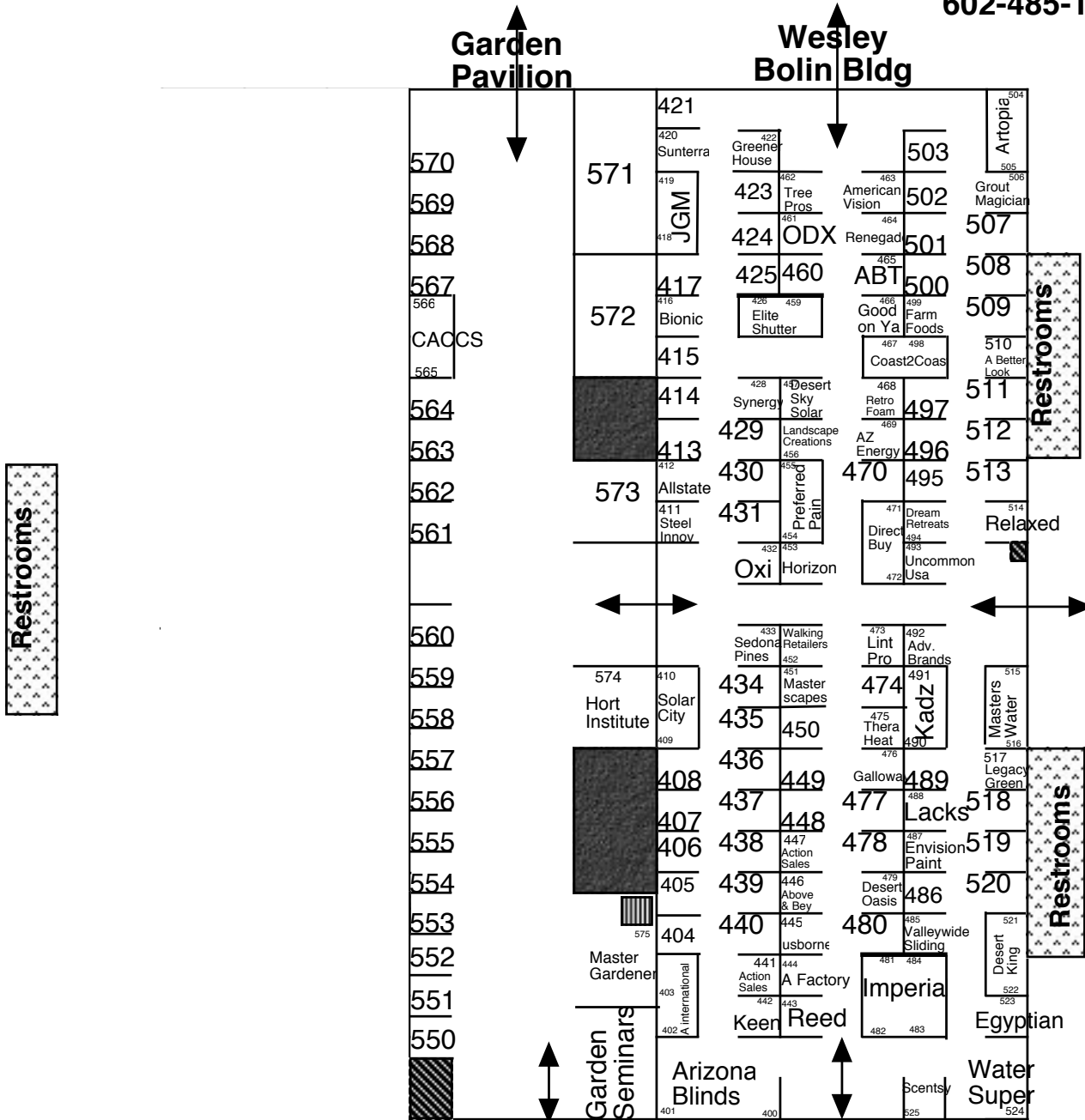

Wesley Bolin Building

All booths are 8x10 / 10 foot frontage and 8 foot depth
\$824.00 inline/ \$1236.00 corner/ Pavilion Corners: 401 & 524 \$2060.00 each

Garden Pavilion

There is a roof overhead and walls on the north and south sides.
The east and west are ornamental iron gates. This building is open air and asphalt flooring. 10x10-Booth # 550-570 Inlines: \$772.50 Corners: \$927.00 Pavilion Corners: 573-576 20x20 \$2060.00; 572 20x30 \$3090.00

Multiple Booth Discount

2-5 Booths - 10% discount
6 or more booths - 15% discount
All booths plus 2.6% tax

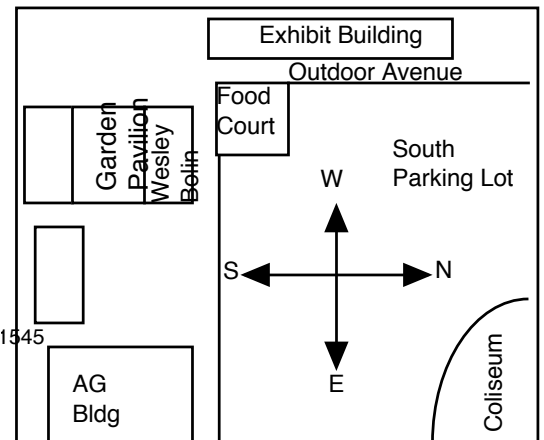

A deposit is required to hold booth a space and custom payment plans are available. Ask your account manager.

MARICOPA COUNTY HOME & LANDSCAPE SHOW

September 28-30, 2012
Arizona State Fairgrounds
602-485-1691

Exhibit Building

All booths are 10x10 or multiples there of.
Inline \$1030.00
Corners \$1545.00
Pavilion Corners are 10x30 in a "L" shape
Booth #: 100, 182, 303, 395 \$2575.00
Pavilion Booths are already discounted and do not qualify for a further discount.
All booths plus 2.6% tax.

Multiple Booth Discounts

2-5 Booths receive a 10% discount
6 or more receive a 15% discount

Heater Units: Some hang as low as 7 feet from floor.

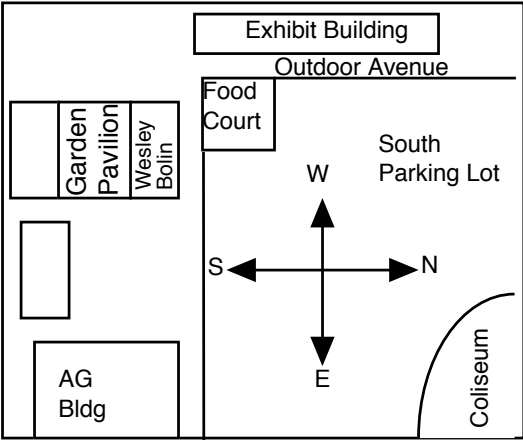
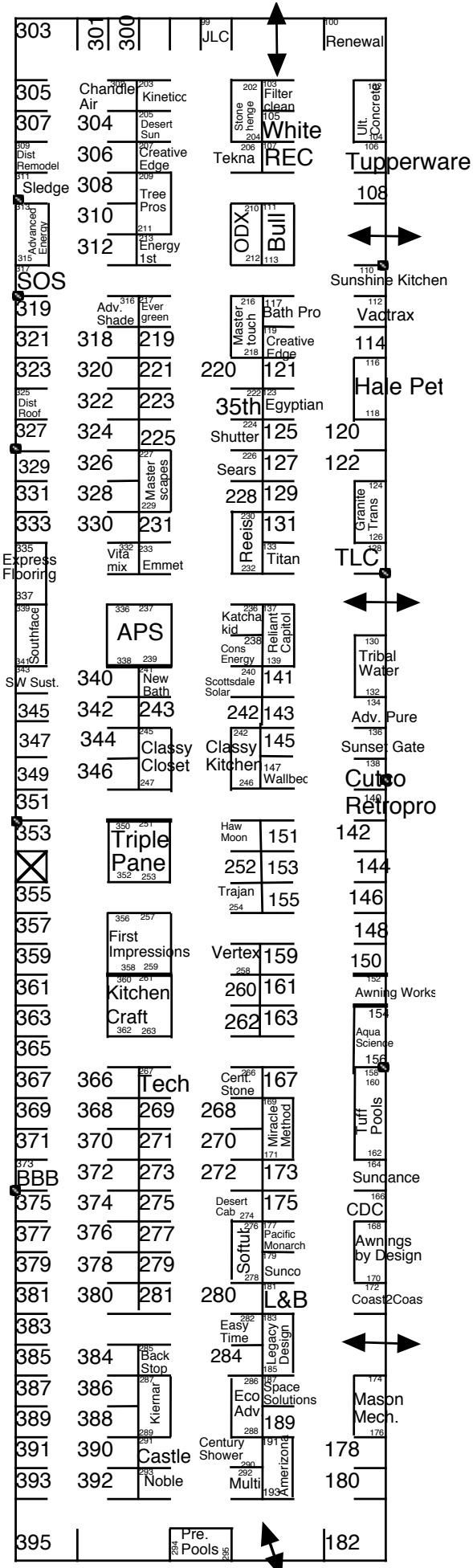

A deposit is required to hold booth a space and custom payment plans are available. Ask your account manager.

Fence

Parking Lot

Parking Lot

Fence

Last update: 5/4/12



Outdoor Booths
 P1-P22
 20x20 \$1545
 All booths plus 2.6% tax
 On Black Top
 With No cover

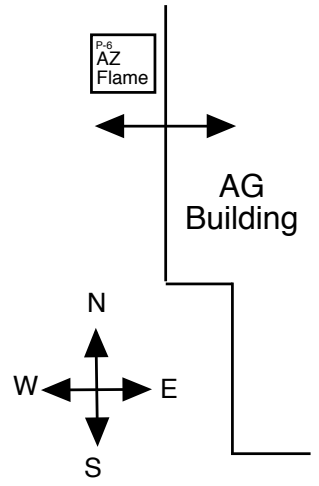
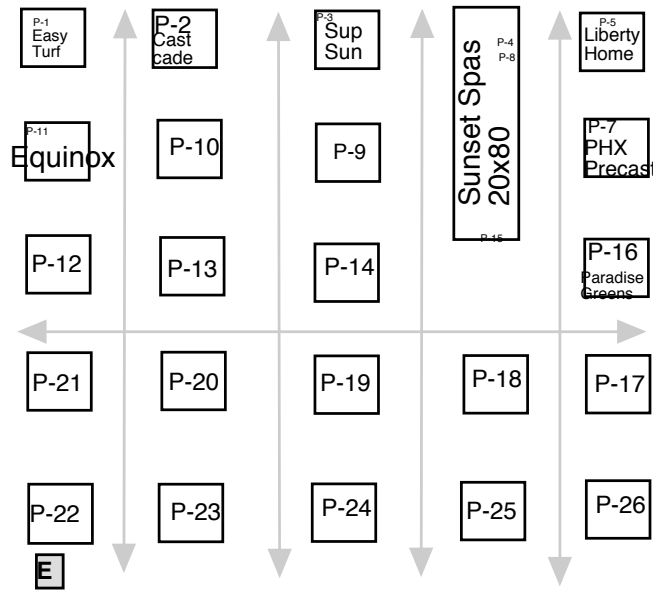

E Electricity
D Drain

September 28-30, 2012
Arizona State Fairgrounds
602-485-1691

Outdoor Companies need to provide protective floor/ground covering protecting venue surfaces from damage. All venue properties shall be left in same condition as upon arrival.

