

Monte Vista Parking Entrance

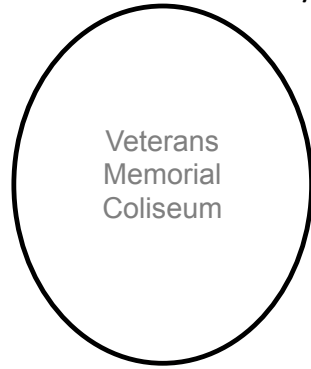

January 11,12,13, 2019
SHOW
OVERVIEW

Vendor parking is located off-site at 19th Ave. & Monte Vista Parking Lots. Free Shuttle service will be provided for all vendors from the Vendor Lots to both show entrances.

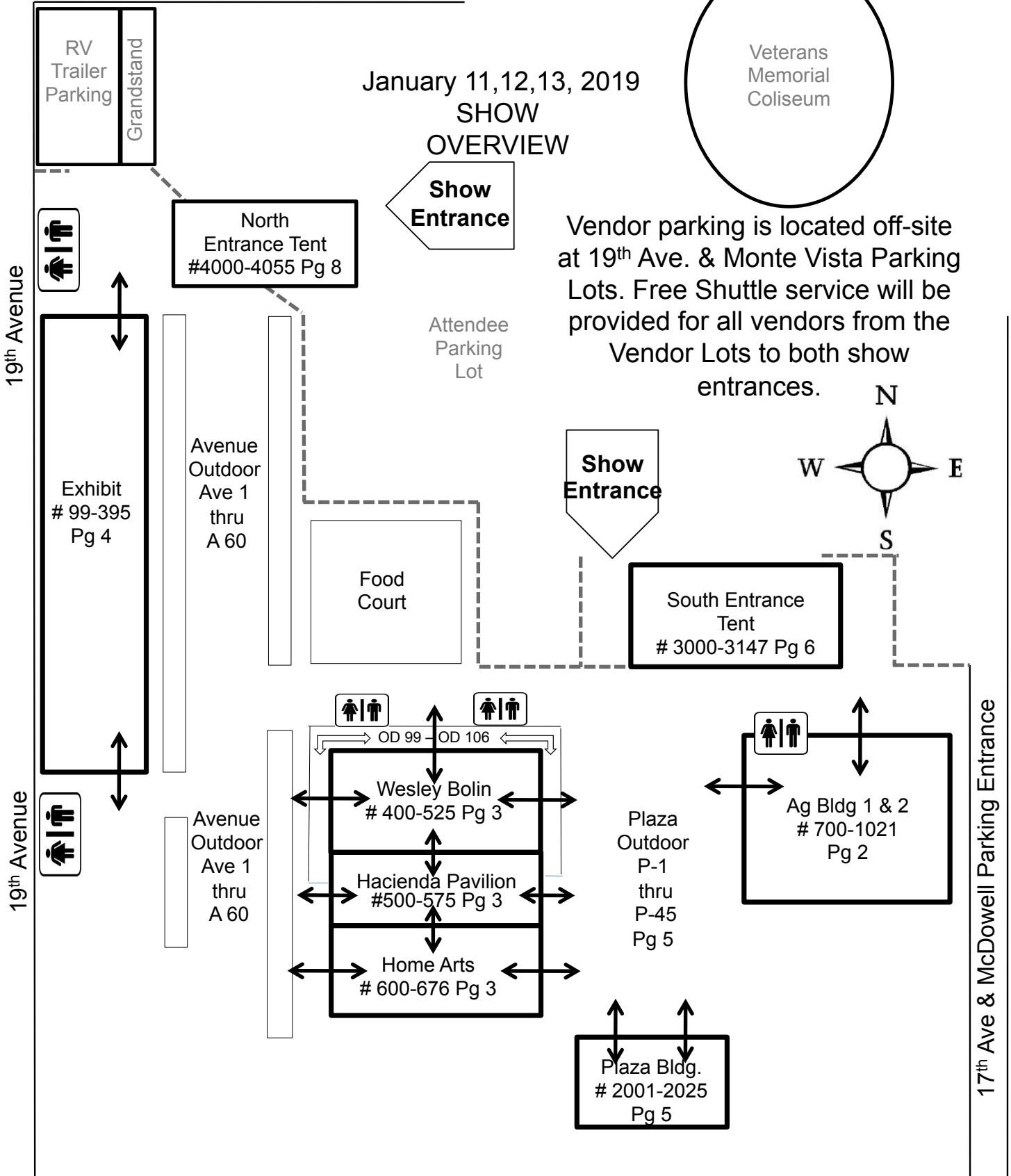
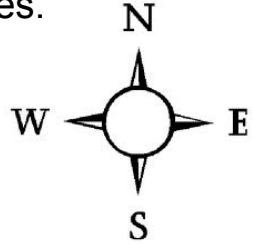

602-485-1691

Maricopa County Home Shows

7/16/18

Agricultural Building

Building Description:

Fully enclosed with concrete flooring. Climate controlled with Evaporative Cooling & Heaters.

8 x 10's = 700-713, 746-773, 806-832, 1005, 1007, 1009, 1011, 1013, 1015, 1017, excluding 821-827

Inline: \$953
Corner: \$1428

10 x 10's = All other booth numbers unless on Miscellaneous list:

10 x 10 Inline: \$1191
10 x 10 Corner: \$1786

Miscellaneous = #'s & Pricing below:

- #847 168sq. Ft. Pavilion Corner: \$3040.16
 - #829 8x14 Corner: \$2273
 - #831 & 1001 Pavilion Corner: \$2575
 - #865 & 871 8x16 Endcap: \$2287
 - #859 5x30 endcap \$2500
 - #849 5x10 Corner \$893
- All Booths Plus 2.6 % Tax

Multiple Booth Discount:

- 2- 5 booths: 10%
- 6 + booths: 15%

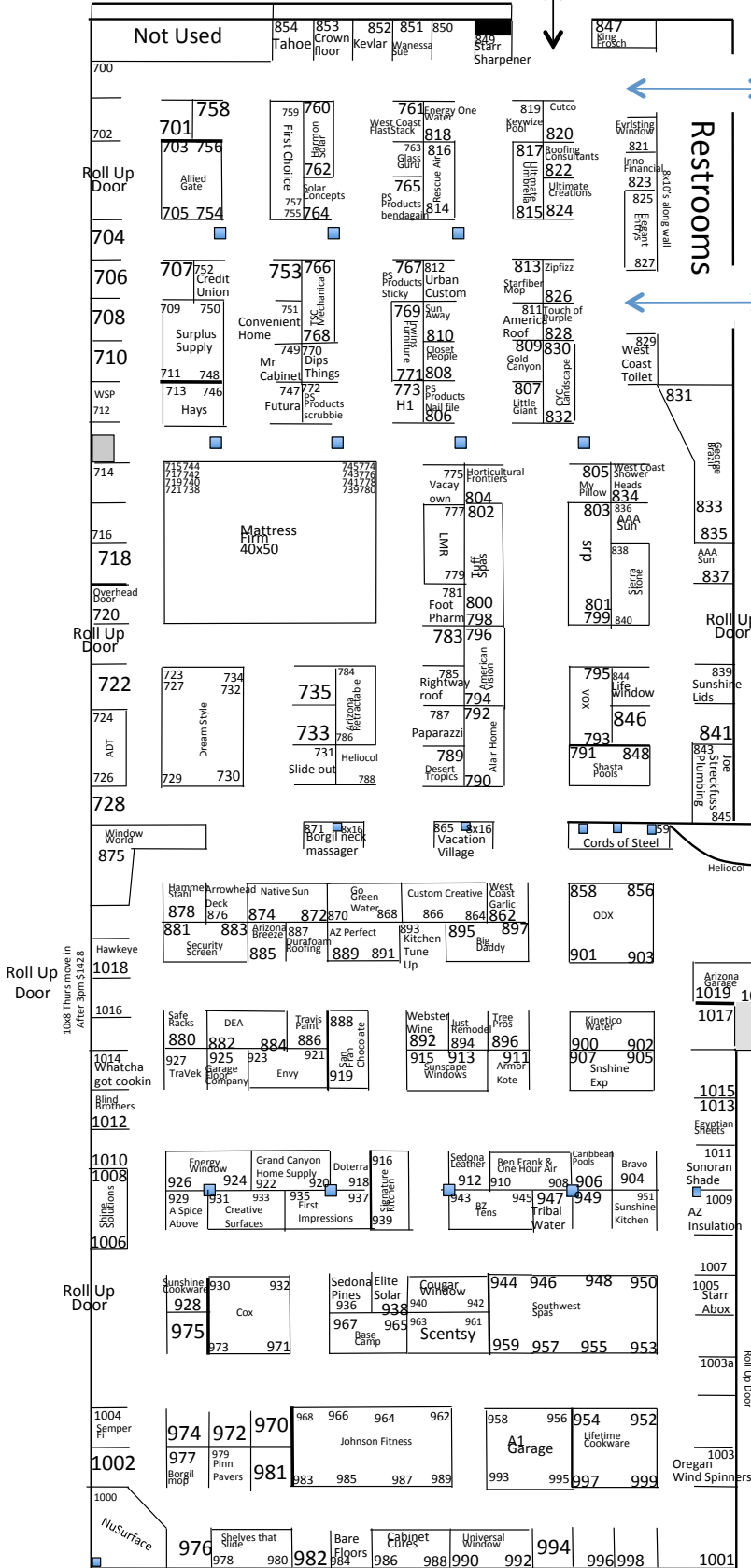

Restrooms

Show Entrance

■ = Structural Support Pillar- approx 2'x2'. Pillar location is approximate and map is not to scale.

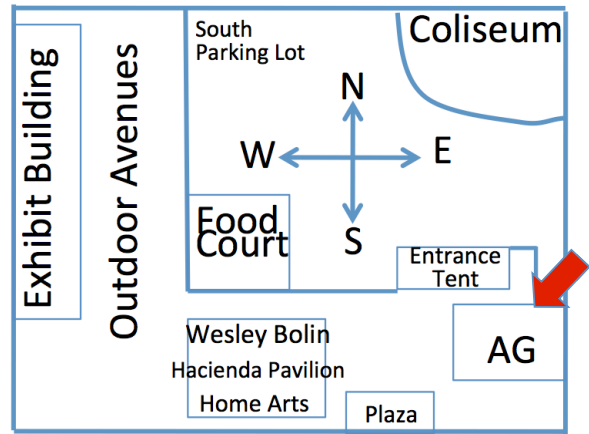

Area Description: These are 3 Separate Buildings that share the same roof and side-walls. This is the middle of the Show between both gated entrances and directly in front of the food court.

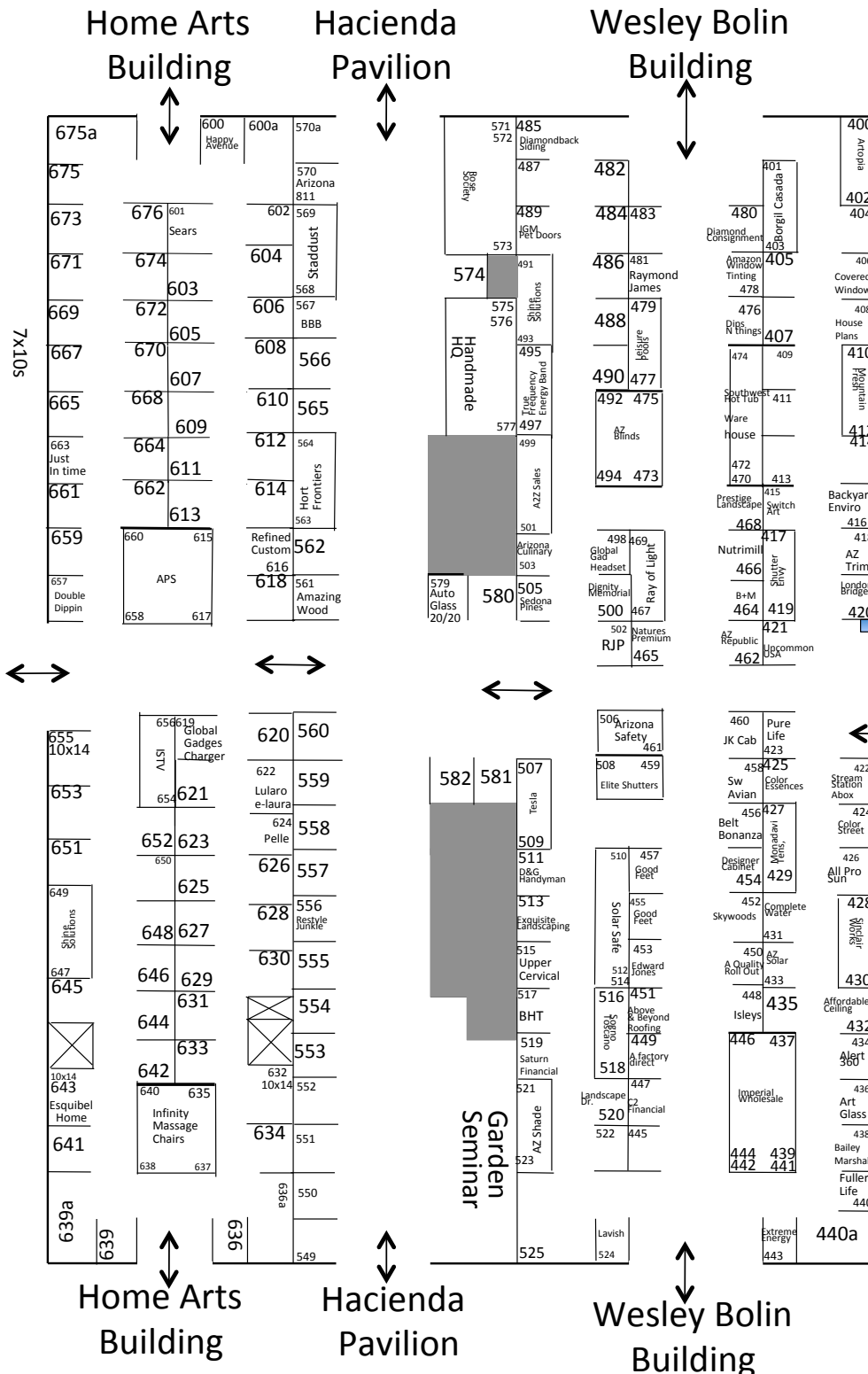

Wesley Bolin: Fully enclosed with concrete flooring. Climate controlled with Evaporative Cooling & Heaters.
8 x 10's
 Inline: \$953
 Corner: \$1428
 Pavilion Corners 525
 approx 240 sq ft.: \$2060.00
 440a-8x20 w/ 10ft opening-\$1465

Hacienda Pavilion: Has roof & side walls and is open-air breezeway with gates on either end, black top flooring. No climate control.
10 x 10's
 Inline: \$850
 Corner: \$1020
 586-589: 10 wide x8 deep open on all 3 sides \$1020
 590, 591: 6 wide x 10 deep , open on all 3 sides \$765

Home Arts: Fully enclosed with concrete flooring. No Climate control.
10 x 10's = 601-637, odds 641-655, evens 658--675
 Inline: \$1191
 Corner: \$1786

7 x 10's = evens 638-656; odds 657-673
 Inline: \$833
 Corner:\$1250

Misc - #'s & Pricing Below:
 643 10 x 14 Inline: \$1667.40
 Pavilion Corners: 600a, 636a, 639a
 Approx 200 sq ft \$1947.60
 #675a Approx 140 sq ft.: \$1786
 #655 10x14 corner:\$2500

Multiple Booth Discount:
 2- 5 booths: 10%
 6 + booths: 15%
 Pavilion Corners do not qualify for multiple booth discounts.

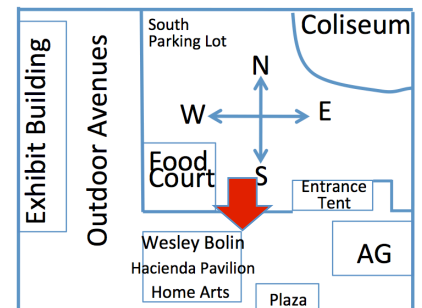

303 New A/c	301 Liberty Mutual	300 Boogie Woogie	99 JLC	100 True View Window
305 Mike Home Store	302 Borgert	201 Waterco		102 Journey Contract
307	304 Arlington	203 Works		104 Arlington
309 Zul Roofing	306 Procraft	205 Door Works		106 Deser Designer
313 Select Premium Granite	310 West Coast	207 Arizona		108 Legends Garage
315 Forward Arch	314 West Coast	209 Window Washer		110 Gen Phone cords
317	313 Armor-Kote			112 EOP Energy
319 Bellini Window	316 Tree Post	211		115 Exotid.14 Scapes
321	318 Paradise	212		116 Vactrax
323 Premier Pooling	320 Steel Shield	219		118 Vactrax
325	324 Sunshine Kitchen	223		120 Gentry
327 Flooring	326 Specialty	225		122 Franklin
329	328 Hawaiian	227		124 Sun Valley Bees
331	330 Moon	229		128 Hale Pet
333	334	233		130 Tone Dog's
335	336	235		132 Pure Plo
337 Paper	338 H2O	237		134 Puro Plo
339	340	239		138 Puro Plo
341 Sunwest	344	243		140 Reno Cooling
343	346	245		142 American Floor
345 Renewal by Andersen	348	247		144 Ferry
347	350	249		146 Ferry
349 Purchase Green	354	253		148 CDC
351 Schlossader	356	255		150 Sun Away
353 Here's Your	358	257		152 Awning Work
355 Integrity Financial	360	259		154 Desert View Landscape
357 Montenegro	362	261		156 Tomplate
359	366	263		158 Wenegade
361 Capital Bath	368	265		160 Alea Mari
363	370	267		162 Floorcens
365 Exhance	374	271		164 Kitchen Tune Up
367 Empire's	376	273		170 Awhic
369 Lifepack	378	275		172 Awhic
371 Preventative Pest	380	277		174 Awhic
373 Blacky	384	281		176 Rainbow
375	386	283		178 USA Cabinets
377 Floor	388	285		180 USA Cabinets
379 Cabinets Less	390	287		182 USA Cabinets
381	392	289		
383 Shiffans	395	291	290	184
385				
387				
389				
391 Grand Materials				
393				

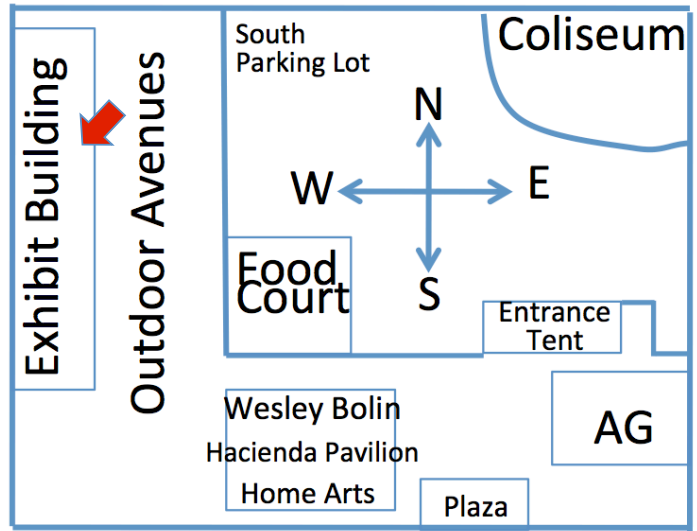

Exhibit Building

Building Descriptions:

Fully enclosed with concrete flooring. Climate controlled with Evaporative Cooling & Heaters. Heating Units are marked with ■ and some hang as low as 7 feet from the floor. All Booths are 10 x 10 or multiples there of with the exceptions of Booths 100, 303, & 395 which are Pavilion Corners (approximately 300 sq feet).

Pricing:

10 x 10 Inline: \$1191
 10 x 10 Corner: \$1786
 Pavilion Corners: \$2575.00
 184 = 10x20 corner: \$2143
 All Booths Plus 2.6 % Tax

Multiple Booth Discount:

2- 5 booths: 10%
 6 + booths: 15%

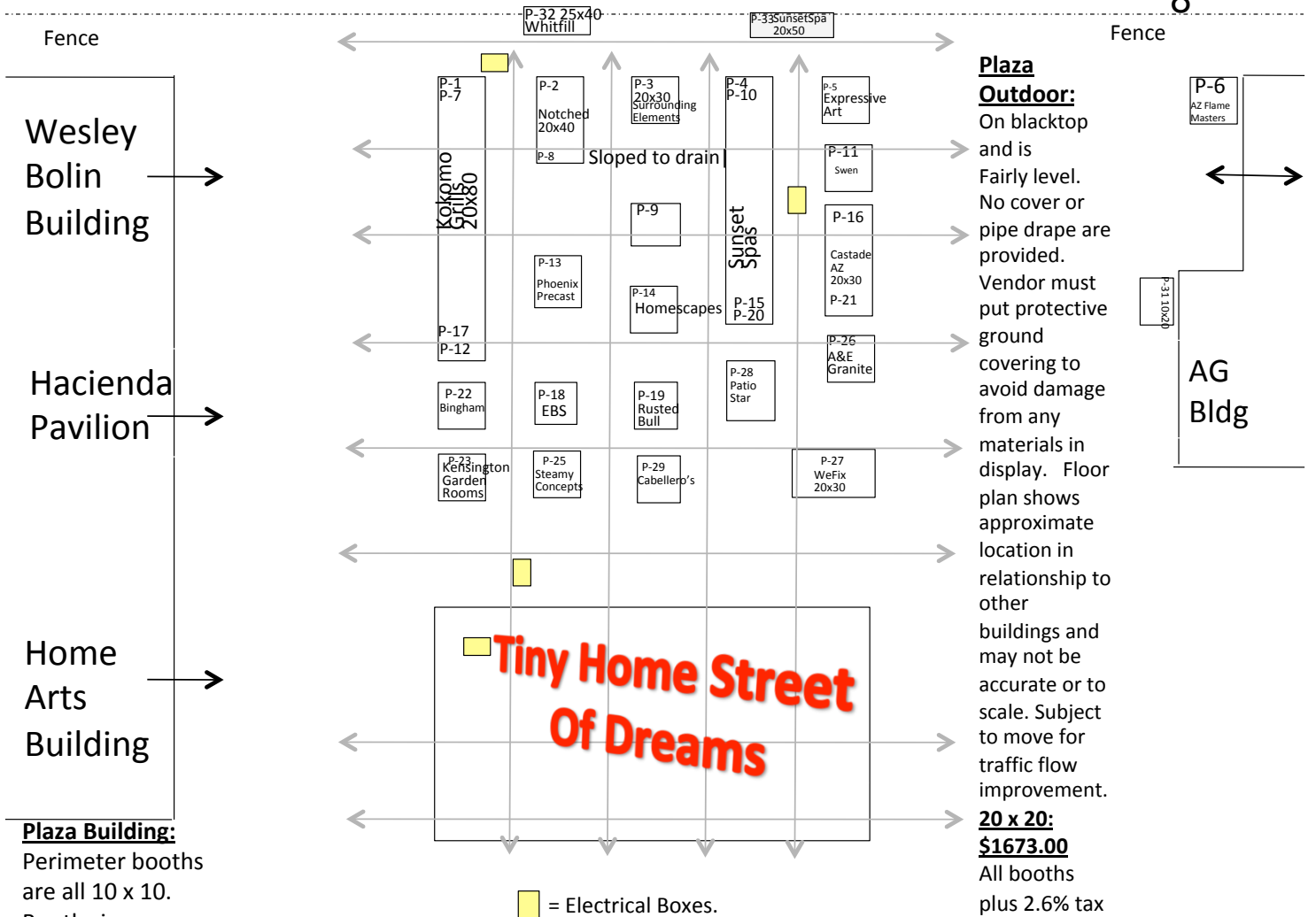

Plaza Building:

Perimeter booths are all 10 x 10. Booths in rows are all 6 x 10

10 x 10's:

Inline: \$1191
Corner: \$1786

6 x 10's:

Inline: \$715
Corner: \$1071

Pavilion Corners:

#2100 \$2143
#2001 & 2014 \$1947.60 ea
All Booths Plus 2.6 % Tax

Multiple Booth Discount:

2- 5 booths: 10%
6 + booths: 15%

Pavilion Corner + outdoor booths do not qualify for multiple booth discount.

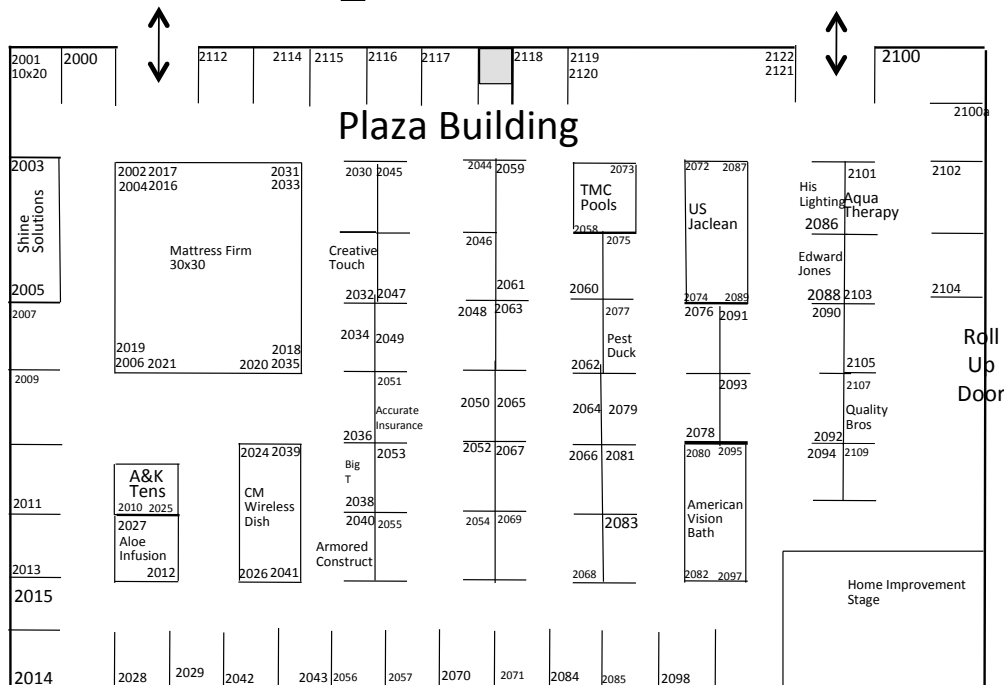

Plaza Building:

Fully enclosed with concrete flooring. Evaporative Coolers only. **NO HEATERS**

X Scooter Rentals

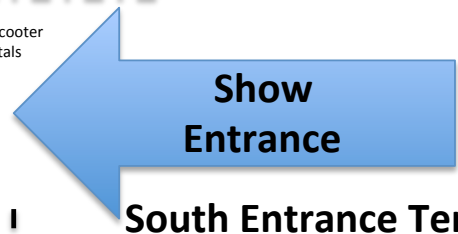
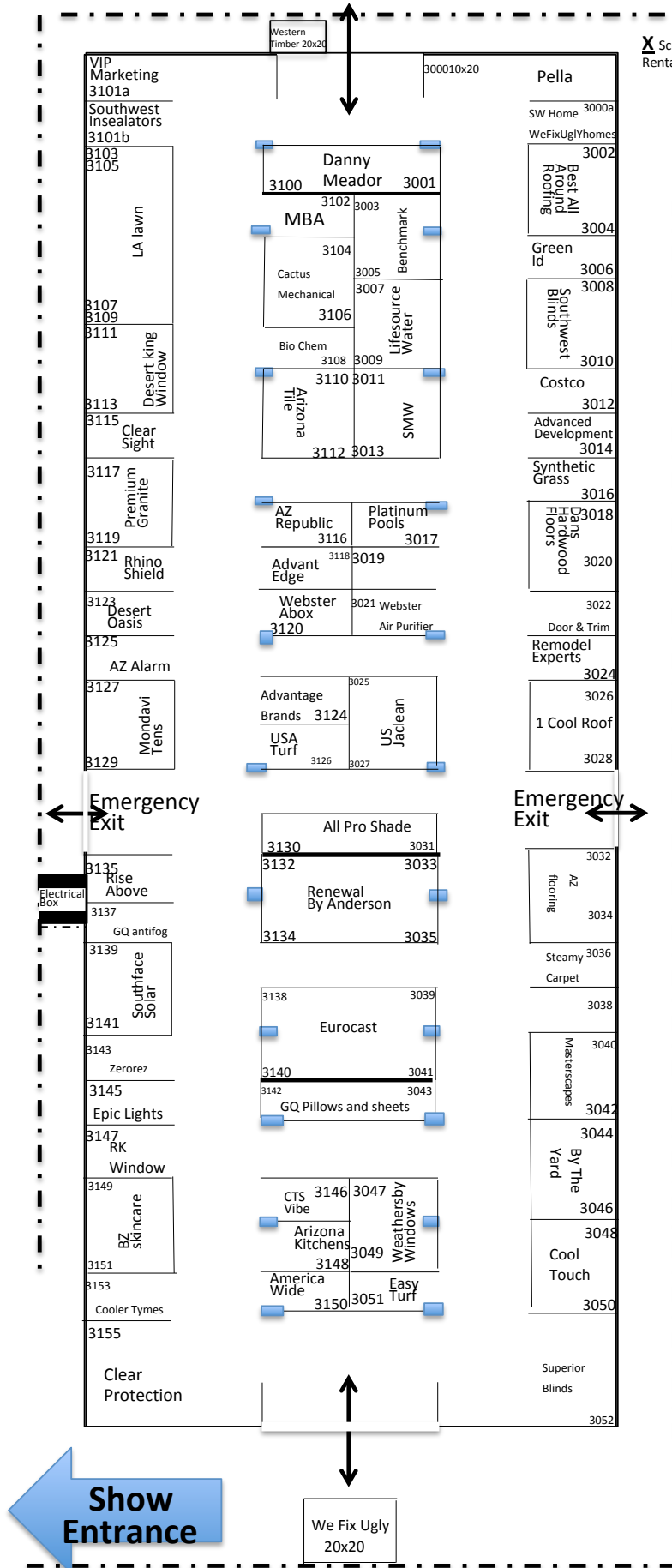

South Entrance Tent

Tent Descriptions:

Fully enclosed on Black Top.
Tent is not climate controlled.
There is overhead lighting and electricity available.

All Booths are 10 x 10 or multiples there of with the exceptions of Booths 3000, 3054, 3155.

■ Indicates Support Pillar

Pricing:

- 10 x 10 Inline: \$1191
- 10 x 10 Corner: \$1786
- Pavilion Corners: \$2575.00
- All Booths Plus 2.6 % Tax
- #3000 and #3054 are 10x20 corner: \$2679.30

Multiple Booth Discount:

- 2- 5 booths: 10%
- 6 + booths: 15%

All center row booths have a tent support pillar, please plan accordingly.

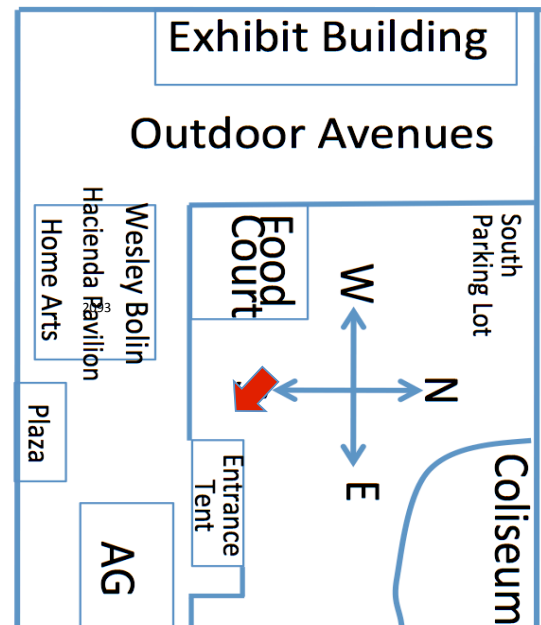

Maricopa County Home Shows

602-485-1691
January 11,12,13, 2019

Avenue Outdoor & Outdoor

Overhang Booths: Booths are 20 x 20 and will be on either dirt & sidewalk, blacktop. No cover or pipe drape are provided. Vendor must put protective ground covering to avoid damage from any materials in display. Floor plan shows approximate location in relationship to other buildings and may not be accurate.

20 x 20 Ave & OD locations: \$1673

20 x 20 Under Overhang: #OD-92-OD-105: \$2060.00

All booths plus 2.6% tax.
Outdoor Booths are already sold at a Discount and do not qualify for the multiple booth discount.

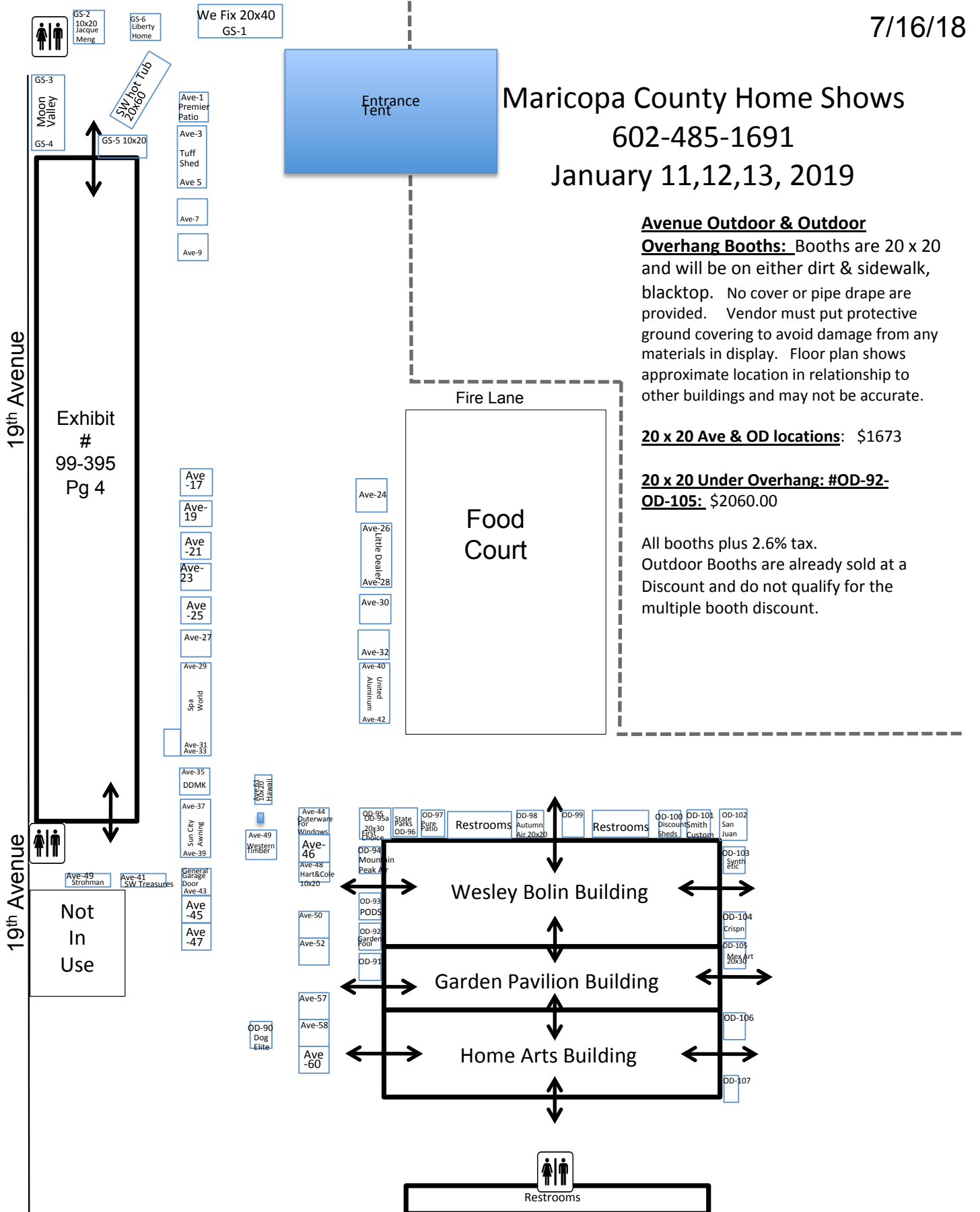

Maricopa County Home Shows
602-485-1691
January 11,12,13, 2019

North Entrance Tent

Tent Descriptions:

Fully enclosed on Black Top.
Tent is not climate controlled.
There is overhead lighting and electricity available.

All Booths are 10 x 10 or multiples there of with the exceptions of Booths #'s 4000, 4015, 4040, 4055

Pricing:

10 x 10 Inline: \$1191
10 x 10 Corner: \$1786.00
All Booths Plus 2.6 % Tax
#4000, #4015, #4040, and #4055 are 10x20 corners: \$2678

All Booths Plus 2.6 % Tax

Multiple Booth Discount:

2- 5 booths: 10%
6 + booths: 15%
Indicates Support Pillar
All center row booths have a tent support pillar, please plan accordingly.

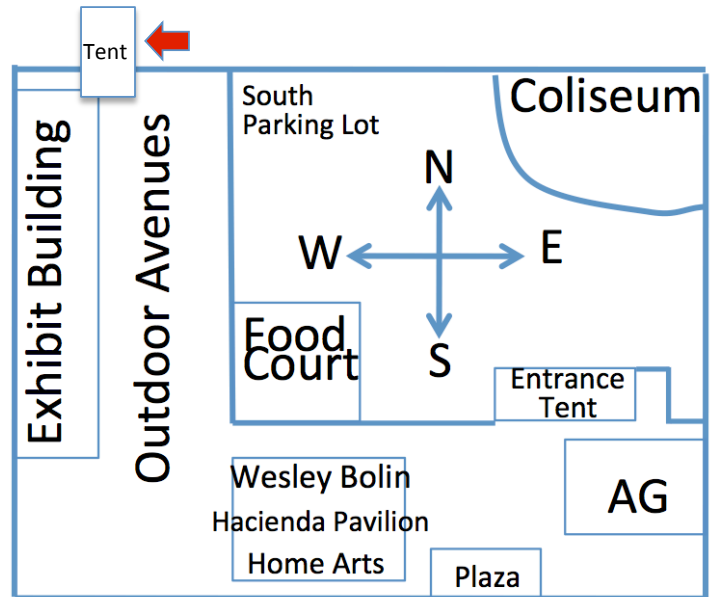
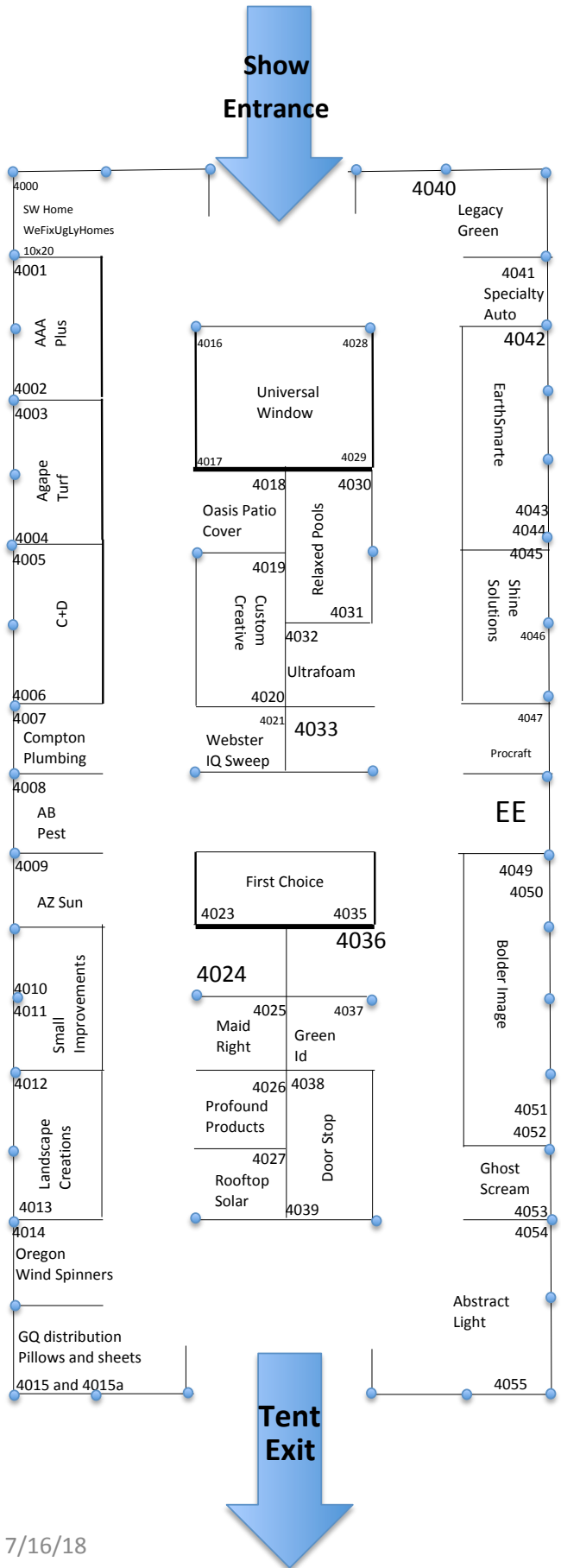

7/16/18

Arizona State Fairgrounds