

Monte Vista Parking Entrance

January 7-9, 2022 SHOW OVERVIEW

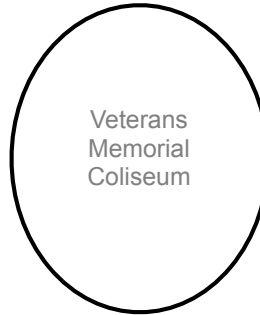

Vendor parking is located off-site at 20th Ave. & Encanto Parking Lots. Free Shuttle service will be provided for all vendors from the Vendor Lots to both show entrances.

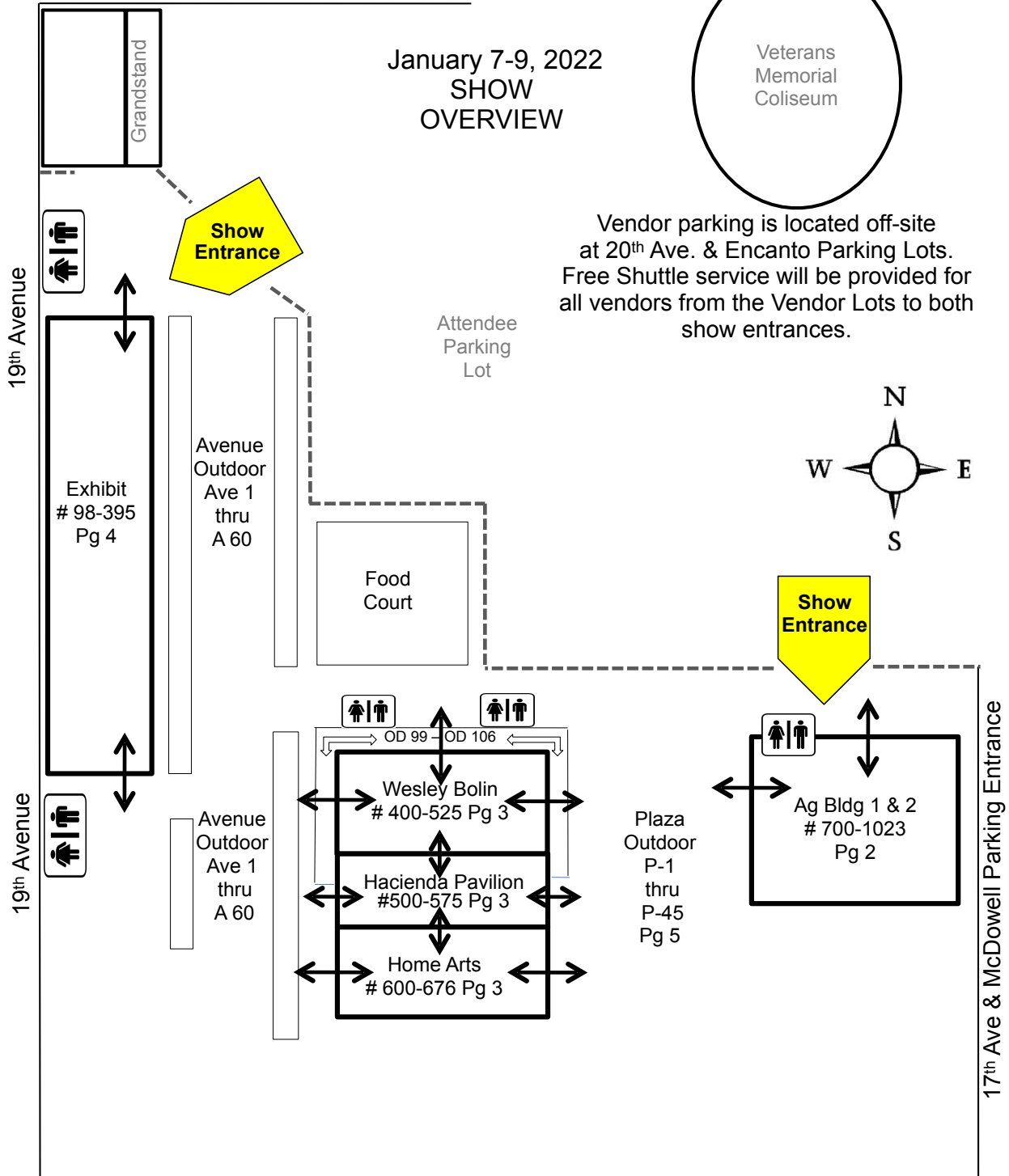

Agricultural Building

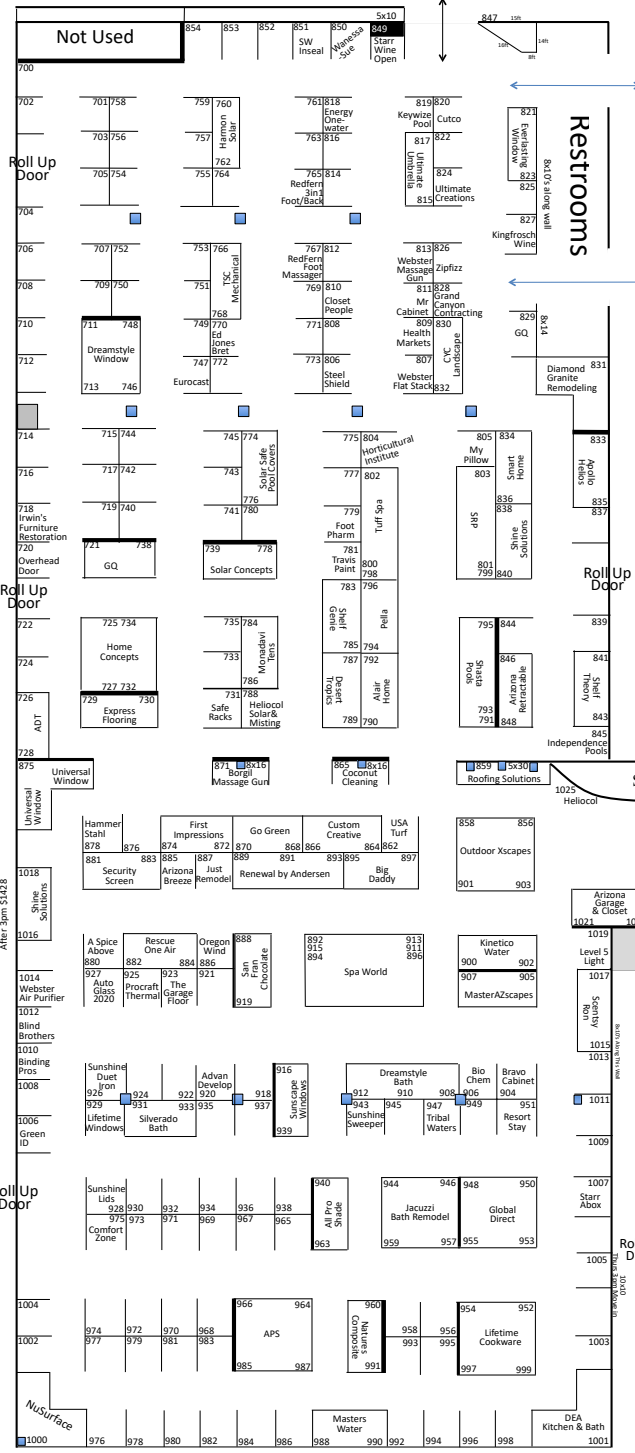

Building Description:

Fully enclosed with concrete flooring. Climate controlled with Evaporative Cooling & Heaters.

8 x 10's = 700-713, 746-773, 806-832, 1007, 1009, 1011, 1013, 1015, 1017, 1019

Inline: \$953
Corner: \$1428

10 x 10's = All other booth numbers unless on

Miscellaneous list:

10 x 10 Inline: \$1191
10 x 10 Corner: \$1786

Miscellaneous = #'s & Pricing below:

- #829 8x14 Corner: \$2273
- #847 168sqft. Pavilion Corner: \$3040.16
- #849 5x10 Corner \$893
- #859 5x30 Endcap: \$2500
- #831, 875, 1000 & 1001 Pavilion Corner: \$2575
- #865 & 871 8x16 Endcap: \$2287
- All Booths Plus 2.6 % Tax

Multiple Booth Discount:

- 2- 5 booths: 10%
- 6 + booths: 15%



■ = Structural Support Pillar - approx 2'x2'. Pillar location is approximate and map is not to scale.

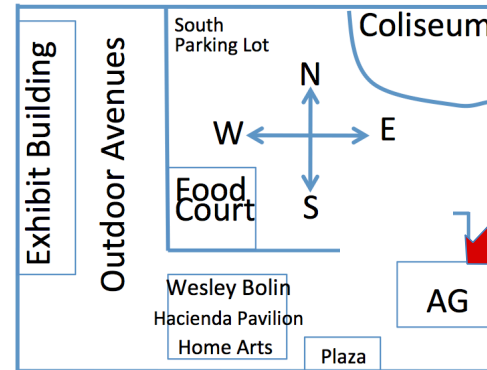

Area Description: These are 3 Separate Buildings that share the same roof and side-walls. This is the middle of the Show between both gated entrances and directly in front of the food court.

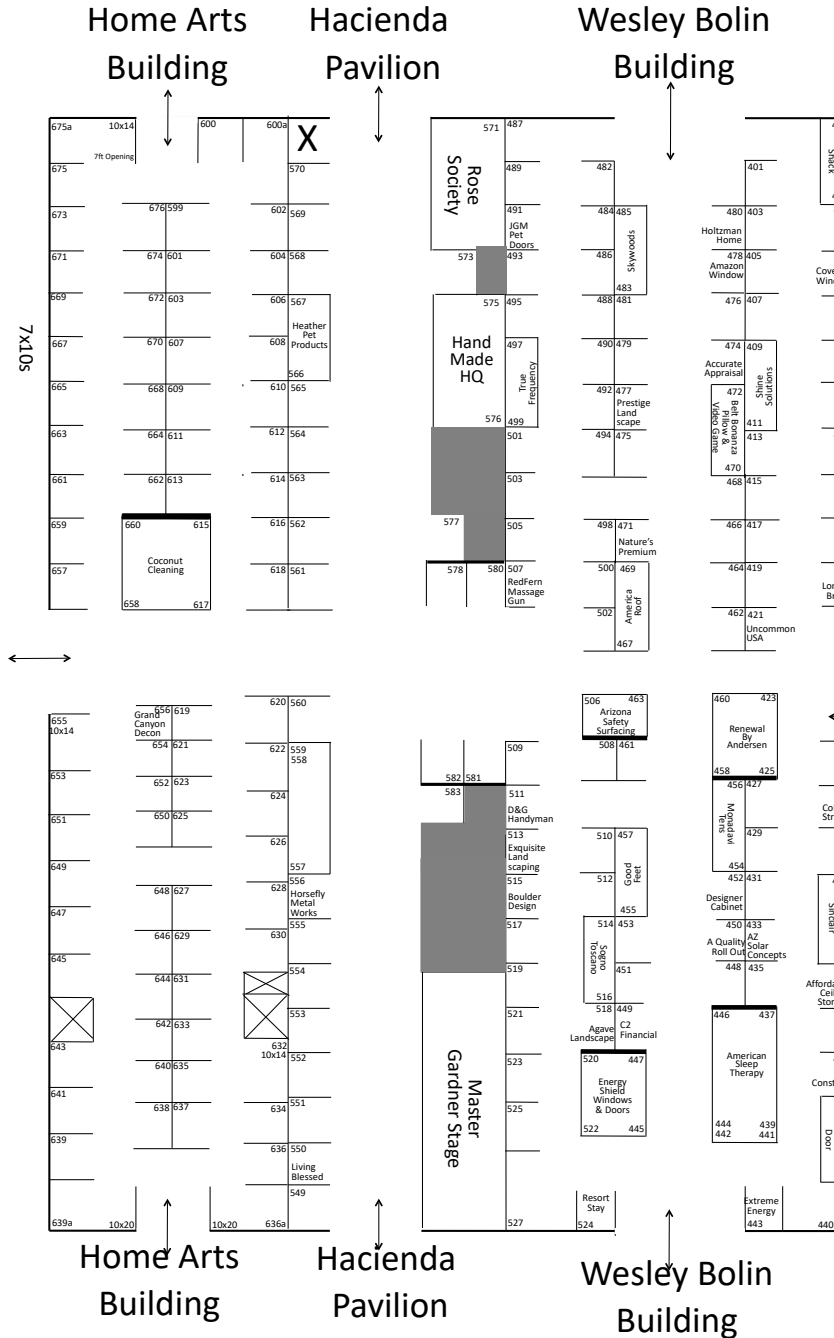

Wesley Bolin: Fully enclosed with concrete flooring. Climate controlled with Evaporative Cooling & Heaters.

8 x 10's
 Inline: \$953
 Corner: \$1428
 Pavilion Corner: 527 approx. 240sqft \$2060
 440a: 8x20 w/ 10ft opening \$1465

Hacienda Pavilion: Has roof & side walls. Open-air breezeway with gates on either end, black top flooring. No climate control.

10 x 10's
 Inline: \$850
 Corner: \$1020
 586-589: 10 wide 8 deep open on all 3 sides \$1020
 590, 591: 6 wide 10 deep open on all 3 sides \$765

Home Arts: Fully enclosed with concrete flooring. No Climate control.

10 x 10's = 600-637, odds 641-653, evens 658-676

→ Inline: \$1191
 Corner: \$1786

7 x 10's = evens 638-656; odds 657-675
 Inline: \$833
 Corner: \$1250

Misc #'s & Pricing Below:

632 & 643 10x14 Inline: \$1667.40
 600a & 639a 10x20 Corner Approx. 200sqft: \$1947.60
 675a 10x14 Corner 7ft Open Approx. 140sqft: \$1786
 655 10x14 Corner: \$2262.40
 636a 10x20 Pavilion Corner: \$2680

Multiple Booth Discount:

2-5 booths: 10%
 6+ booths: 15%
 Pavilion Corners do not qualify for multiple booth discounts.

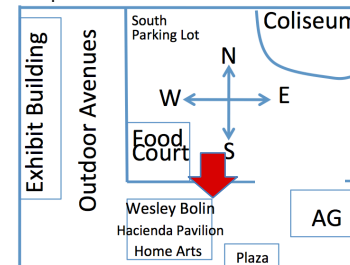

2/23/21

Show Entrance

Maricopa County Home Shows
602-485-1691
Arizona State Fairgrounds

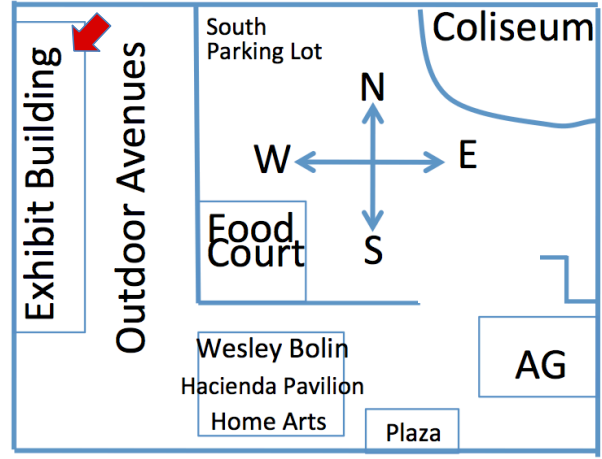
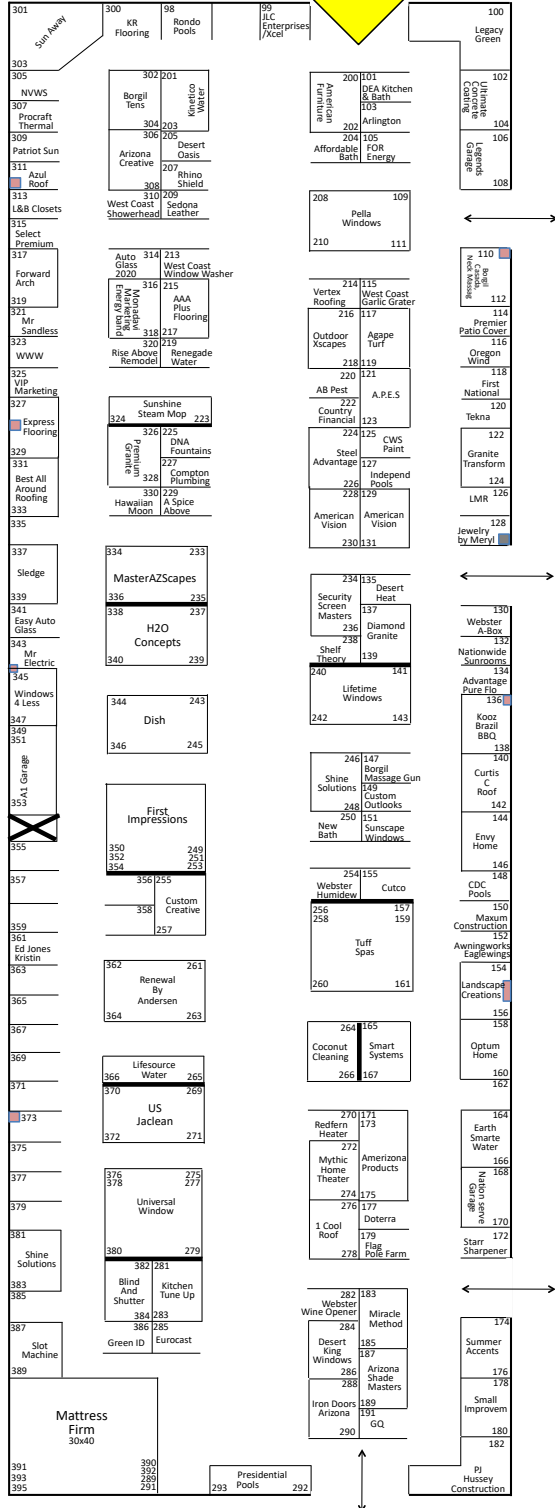

Exhibit Building

Building Description:
Fully enclosed with concrete flooring.
Climate controlled with Evaporative Cooling & Heaters. Heating units are marked with ■ and some hang as low as 7 feet from the floor.
All Booths are 10 x 10 or multiples there of with the exceptions of Booths 100, 182, & 395 which are Pavilion Corners (approximately 300 sq feet).

Pricing:
10 x 10 Inline: \$1191
10 x 10 Corner: \$1786
100, 395, & 182 Pavilion Corners: \$2575.00
301 6x20 Corner: \$1429.20
All Booths Plus 2.6 % Tax

Multiple Booth Discount:
2- 5 booths: 10%
6+ booths: 15%



☐ = Electrical Boxes.

Plaza Outdoor:

On blacktop and is fairly level. No cover or pipe drape are provided. Vendor must put protective ground covering to avoid damage from any materials in display. Floor plan shows approximate location in relationship to other buildings and may not be accurate or to scale. Subject to move for traffic flow improvement.

20 x 20: \$1673.00

All booths plus 2.6% tax

Plaza Building:

Perimeter booths are all 10 x 10. Booths in rows are all 6 x 10

10 x 10's:

Inline: \$1191
Corner: \$1786

6 x 10's:

Inline: \$715
Corner: \$1071

Pavilion Corners:

#2100 \$2143
#2001 & 2014 \$1947.60 ea
All Booths Plus 2.6 % Tax

Multiple Booth Discount:

2- 5 booths: 10%
6 + booths: 15%

Pavilion Corner + outdoor booths do not qualify for multiple booth discount.

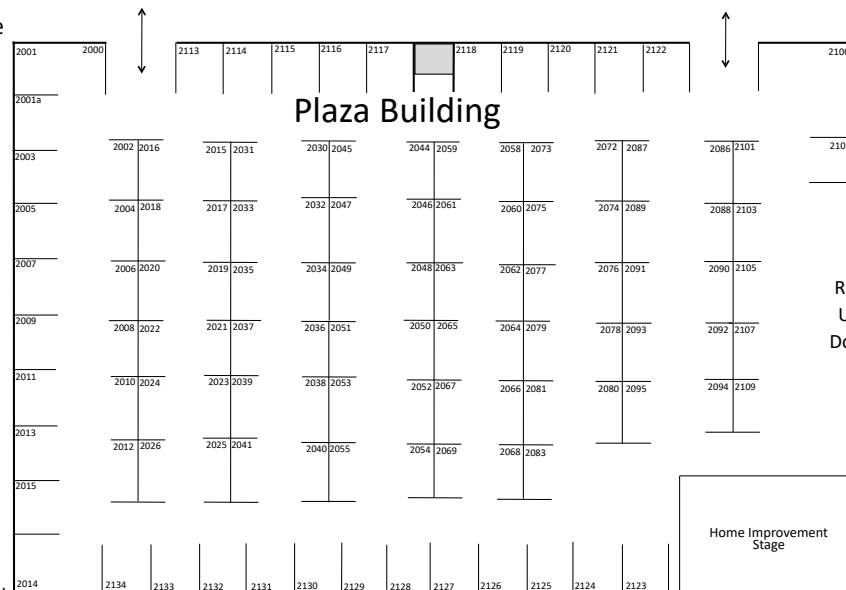

Plaza Building:

Fully enclosed with concrete flooring. Evaporative Coolers only. **NO HEATERS**

Maricopa County Home Shows
602-485-1691
January 8-10, 2021

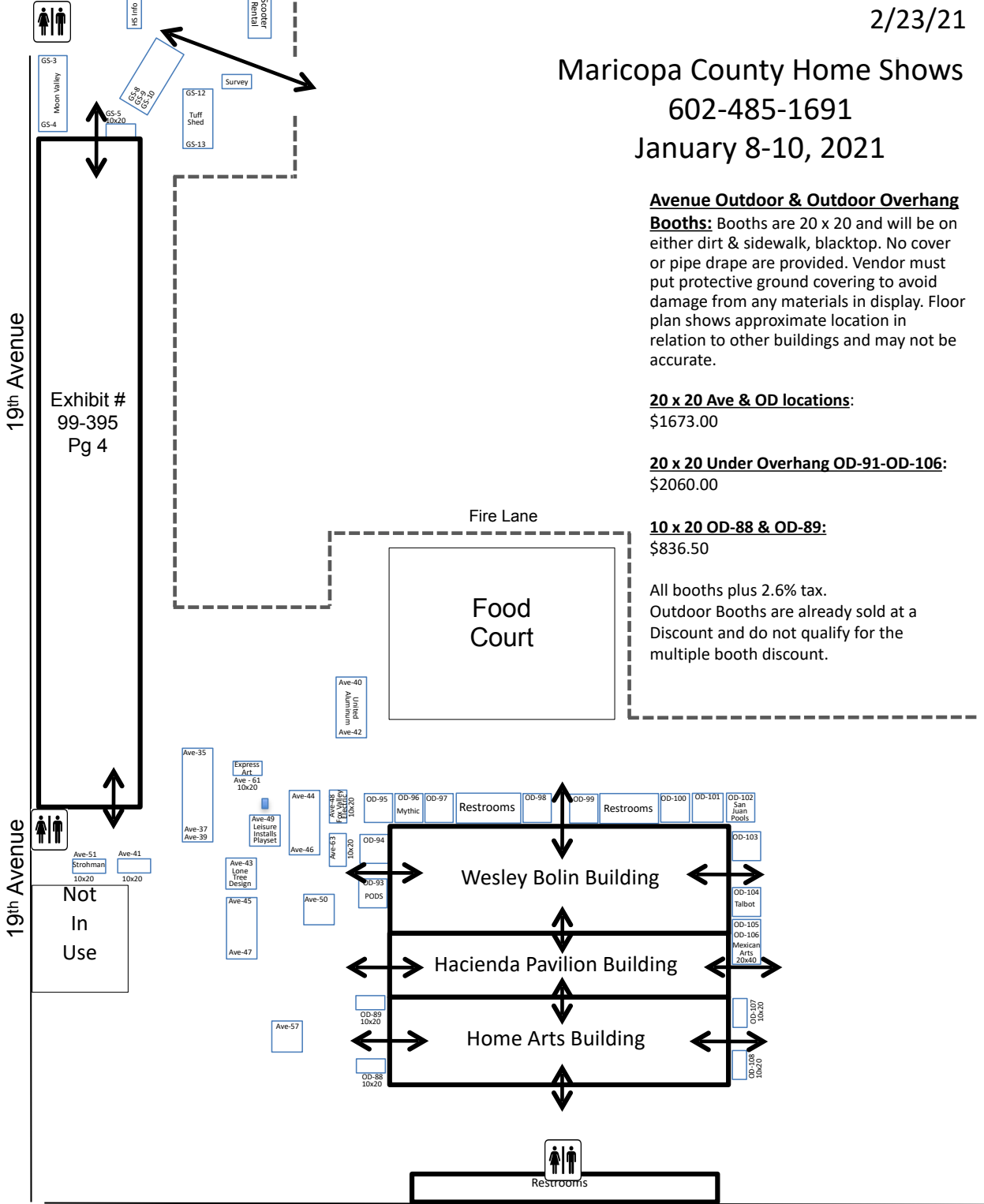

Avenue Outdoor & Outdoor Overhang Booths: Booths are 20 x 20 and will be on either dirt & sidewalk, blacktop. No cover or pipe drape are provided. Vendor must put protective ground covering to avoid damage from any materials in display. Floor plan shows approximate location in relation to other buildings and may not be accurate.

20 x 20 Ave & OD locations:
\$1673.00

20 x 20 Under Overhang OD-91-OD-106:
\$2060.00

10 x 20 OD-88 & OD-89:
\$836.50

All booths plus 2.6% tax.
Outdoor Booths are already sold at a Discount and do not qualify for the multiple booth discount.